

High visibility with 5.7inch wide screen Graphic panel GP-S057

■ Features

- Displays max. 1590 characters
- Enables to save max. 500 pages of user screen
- Easy software upgrade at website
 - (1) GP firmware file
 - (2) GP Editor(drawing program)
 - (3) Additional protocol
- Different devices monitoring function
 - : PLC port allows to monitor and control the variables of additionally connected controllers
- Supports multilingual
 - : Supports Korean, Japanese, English, Chinese, Russian, Vietnamese and Portuguese.
 - Additional languages will be available by firmware.
- Supports multi-font
 - : It provides various bitmap and user-selected fonts.
- Various multi-communication port
 - : Both RS232C 2 port or RS232C/RS422 compound port are provided.
- Device monitoring function
 - : It enables to monitor GP devices and connected controller devices by GP without graphic design data.
- Printer and barcode reader connection
 - : It enables to print alarm history connecting a printer and read barcode connecting a barcode reader.
- Compact design
 - : Minimizes module size and installation places by 5.7 inch display area
- Various display function
 - : It displays data by various tags.



5.7 inch
MONO

 Please read "Caution for your safety" in operation manual before using.



■ Manual

Visit our webwite(www.autonics.com) to download 'GP Editor user manual' or 'GP, LP user manual for communication', 'GP-S044/S057 user manual'.



- **GP Editor user manual**
It describes how to write screen data, and is about related usage of GP-S057 HMI function.
- **GP, LP user manual for communication**
It describes connection for external devices such as PLC.
- **GP-S044/S057 user manual**
It describes general information on the installation and usage of GP-S057 and system contents.

■ Ordering information

Model	Item	Series	Monitor size	Display unit	Color	Power supply	Interface
GP-S057-S1D0	Graphic panel	S series	5.7 inch	STN LCD	MONO (blue, white)	24VDC	RS232C, RS422 (1EA for each)
GP-S057-S1D1							RS232C (2EA)

(A)	Photo electric sensor
(B)	Fiber optic sensor
(C)	Door/Area sensor
(D)	Proximity sensor
(E)	Pressure sensor
(F)	Rotary encoder
(G)	Connector/Socket
(H)	Temp. controller
(I)	SSR/ Power controller
(J)	Counter
(K)	Timer
(L)	Panel meter
(M)	Tacho/ Speed/ Pulse meter
(N)	Display unit
(O)	Sensor controller
(P)	Switching mode power supply
(Q)	Stepper motor& Driver&Controller
(R)	Graphic/ Logic panel
(S)	Field network device
(T)	Software
(U)	Other

■ Specifications

Model	GP-S057-S1D0		GP-S057-S1D1
Power supply	24VDC		
Allowable voltage range	90 to 110% of power supply		
Power consumption	Max. 3.6W		
Display performance	LCD type	5.7Inch STN blue negative	
	Resolution	320×240 dots	
	Display area	119mm×91mm	
	Color	MONO(blue, white)	
	LCD view angle	Top/Bottom/Left/Right 30°in each direction	
	Backlight	White LED	
	Brightness	Adjustable by software	
Graphic drawing performance	Language ^{※1}	English, Korean, Japanese, Chinese, Russian, Vietnamese, Portuguese	
	Text	<ul style="list-style-type: none"> • High resolution display up to 1590 letters(6×8 font) • 6×8, 8×8 ASCII character, high definition numbers • 8×16 ASCII characters, 16×16 regional characters(1-8 times bigger for width, 0.5-5 times bigger for height) 	
	Graphic drawing memory	512 KB	
	Number of user screen	500 pages	
	Touch switch	Width 16×Height 12 = 192	
Serial interface	Each port of RS232C, RS422(asynchronous method)	Two ports of RS232C(asynchronous method)	
Real-time controller	RTC embedded		
Battery life cycle	Approx. 3 years at 25°C		
Insulated resistance	Min. 100MΩ(at 500VDC megger)		
Ground	3rd grounding(max. 100Ω)		
Noise resistance	± 0.5kV the square wave noise(pulse width : 1μs) by the noise simulator		
Dielectric strength	500VAC(50/60Hz) for 1 min.		
Vibration	Mechanical	0.75mm amplitude at frequency of 10 to 55Hz(for 1 min.) in each of X, Y, Z directions for 1 hour	
	Malfunction	0.5mm amplitude at frequency of 10 to 55Hz(for 1 min.) in each of X, Y, Z directions for 10 min.	
Shock	Mechanical	300m/s ² (approx. 30G) in each of X, Y, Z directions for 3 times	
	Malfunction	100m/s ² (approx. 10G) in each of X, Y, Z directions for 3 times	
Environ-ment	Ambient temperature	0 to 50°C, storage : -20 to 60°C	
	Ambient humidity	35 to 85%RH, storage : 35 to 85%RH	
Protection ratings	IP65F(for front panel)		
Accessory	Fixing bracket : 4EA, Rubber waterproof ring, Battery(included)		
Approval	 		
Weight ^{※2}	Approx. 555g(approx. 376g)		

※1: Language can be customized.

※2: This weight is with packaging and the weight in parentheses is only unit weight.

※Environment resistance is rated at no freezing or condensation.

■ Functional description

Figure display	Line, rectangle, circle, text, bitmap	
Tags	Numeral display	Displays the designated device as numerical value. (decimal, hexadecimal, octal, binary, real number)
	ASCII display	Displays the designated device value as ASCII character.
	Time display	Displays current time or date.
	Alarm history	Registers alarm history.
	Alarm list	Displays generated (not backed up) alarm.
	Comment display	Displays the designated comment as device status or value.
	Lamp	Displays lamp as device status.
	Part display	Displays the designated parts as device status and value.
	Line graph	Displays several device values with a graph of broken line.
	Trend graph	Displays change of device value for time with a graph of broken line.
	Bar graph	Displays a device value with a bar graph.
	Statistic graph	Displays a ratio of several device values with pie graph.
	Panel meter	Displays a device value as panel meter.
	Touch key	Screen is switched, word/bit device values are set when it touched.
Numeral input	Configures user input value in device.	
ASCII input	Configures user input ASCII code value in device.	
System information function	Monitors/Controls GP operation from PLC.	
Recipe function	Reads/Writes several PLC device collectively.	
Security function	Only acceptable user can observe/operate important data.	
Barcode read function	Connects barcode reader, read barcode.	
Floating alarm function	Warning message is floated when alarm is generated.	
Time operation	Specific bit device is ON/OFF for designated day and time.	
Overlap window	Available to form dynamically overlapping another base screen on the base one.	
Observe status function	Changes PLC device status/value of PLC when trigger is generated.	

Graphic Panel

■ Dimensions

(unit : mm)

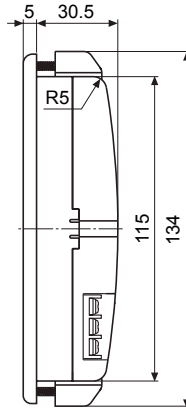
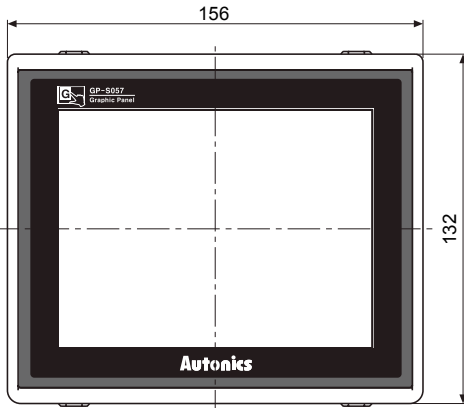
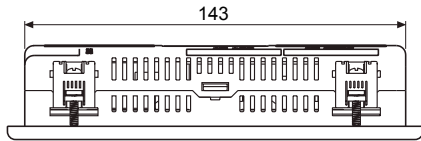

● Panel cut-out

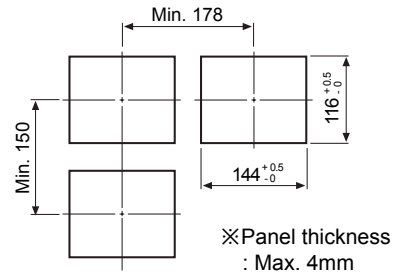

● Fixing bracket

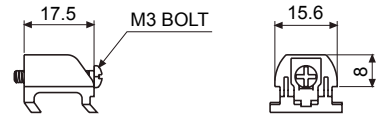

■ Part description

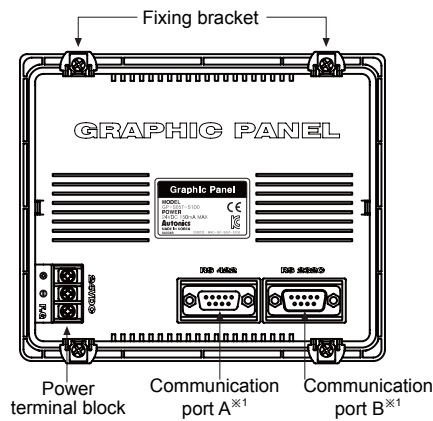

※1: Communication port

Communication port	Port A	Port B
Model	Port A	Port B
GP-S057-S1D0	RS422	RS232C
GP-S057-S1D1	RS232C-A	RS232C-B

※For more information, refer to R-32 page and 'Serial interface' of GP/LP common features.

(A)	Photo electric sensor
(B)	Fiber optic sensor
(C)	Door/Area sensor
(D)	Proximity sensor
(E)	Pressure sensor
(F)	Rotary encoder
(G)	Connector/Socket
(H)	Temp. controller
(I)	SSR/ Power controller
(J)	Counter
(K)	Timer
(L)	Panel meter
(M)	Tacho/ Speed/ Pulse meter
(N)	Display unit
(O)	Sensor controller
(P)	Switching mode power supply
(Q)	Stepper motor& Driver&Controller
(R)	Graphic/ Logic panel
(S)	Field network device
(T)	Software
(U)	Other

GP-S057

■ Installation

1. Set a rubber waterproof ring after placing the ring's joining part under the GP-S057.
2. Adhere closely between each edge of the GP-S057 and the rings.
3. Set GP-S057 in panel.
4. Set the fix bracket to 4 bracket slots and fix them with bracket's screws.

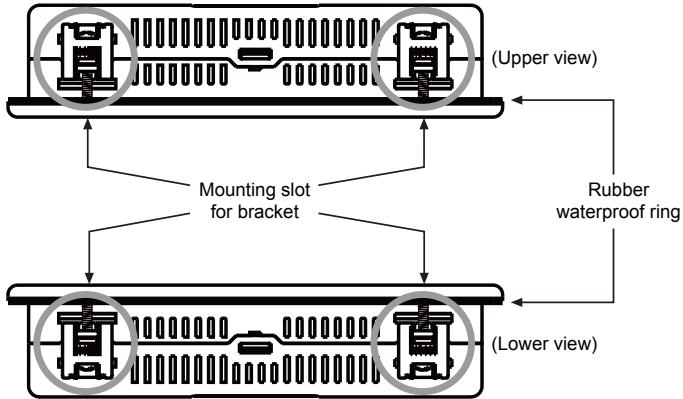

● Mounting bracket

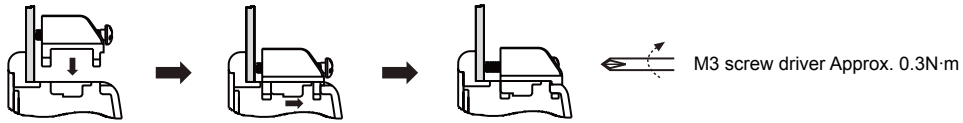

■ Sold separately

Transmission cables connectable into external devices such as PLC are sold separately. (refer to the R-32 page for "GP/LP communication cable".)

GP/LP Common Features

Serial interface

- All devices connectable into LP-S044 including PC, PLC, serial printer, barcode reader and dedicated connectors can be connected into both RS232C and RS422 ports.
- Device must be set for the port in system setting for LP-S044, LP-S070. For details, refer to "GP user manual".
- Use the dedicated communication cable for the each connected device.
(Refer to the "GP/LP communication cable" of R-32 page)
- For the method of wiring external devices of PLC, refer to "GP/LP communication manual".

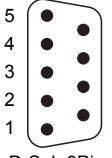
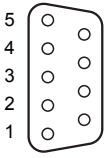
Port	NO.	Pin(GP-S044, GP-S057, GP-S070)	Pin(LP-S044, LP-S070)
RS232C  D-Sub 9Pin Male	1	Non-used	Non-used
	2	RXD	RXD
	3	TXD	TXD
	4	DTR	DTR
	5	SG	SG
	6	DSR	DSR
	7	Non-used	Non-used
	8	Non-used	Non-used
	9	Non-used	Non-used
RS422  D-Sub 9Pin Female	1	TXD+	TXD+
	2	RXD+	RXD+
	3	Non-used	Non-used
	4	Non-used	Non-used
	5	SG	SG
	6	TXD-	TXD-
	7	RXD-	RXD-
	8	Non-used	Non-used
	9	Non-used	Non-used

Power wiring

- For power supply, use the wire of which cross section is at least 0.75mm² and use the wire of which cross section is at least 1.25mm² for grounding.
- Use crimp-on type terminal with at least 3mm of internal diameter and less than 6mm of external diameter.
- Do not apply power before power line connection.
- Check power polarity.
- Tighten the terminal screw with 0.5 to 0.8N·m torque.
- Ground resistance should be less than 100Ω and ground it separately.

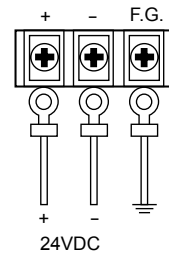

Battery replacement

Please contact out distributor to replace battery.
It may cause an explosion or a fire when improper battery is used.

Caution for using

- Use communication cable after checking whether there is break, short.
- Please install power switch or circuit-breaker in order to cut power supply off.
- Separate this unit from high voltage line, power line to avoid inductive noise.
- Do not use this product at below places.
 - Place where there is severe vibration or impact
 - Place where dust exists, or corrosion causing environments.
 - Place where strong magnetic field or electric noise are generated
 - Place where is temperature/humidity is beyond the specification
 - Place where strong alkalis or vibration or impact
 - Place where there are direct ray of the sun
- Installation environment
 - It shall be used indoor.
 - Altitude Max. 2,000m
 - Pollution Degree 2
 - Installation Category II

(A)	Photo electric sensor
(B)	Fiber optic sensor
(C)	Door/Area sensor
(D)	Proximity sensor
(E)	Pressure sensor
(F)	Rotary encoder
(G)	Connector/Socket
(H)	Temp. controller
(I)	SSR/ Power controller
(J)	Counter
(K)	Timer
(L)	Panel meter
(M)	Tacho/ Speed/ Pulse meter
(N)	Display unit
(O)	Sensor controller
(P)	Switching mode power supply
(Q)	Stepper motor& Driver&Controller
(R)	Graphic/ Logic panel
(S)	Field network device
(T)	Software
(U)	Other

General Features

■ GP(Graphic Panel)?



GP-S044

GP-S057

GP-S070

Graphic panel is HMI(Human Machine Interface) device that parameter monitors or changes via graphic interface by communication with PLC, temperature controller or other control units.

Graphic interface of GP is very effective to indicate value or status of parameter with visual interface that enables the communication between controller and user.

GP is able to monitor parameters virtually with LCD screen, switch screen by touching screen, set or change parameters. GP connecting with controller via serial communication method translates data and displays various control parameters with graphic.

For example, in case of the target of parameters is the temperate, the numerical value of temperature is shown with a tag and the change in temperature for time can be graphed on the screen.

■ Preparation for using GP



The numerical value of temperature



Graph of temperature

- 1) GP body
- 2) PC
- 3) GP Editor
 - Software for drawing GP screen
- 4) Manual
 - GP editor user manual
 - LP, GP Communication manual
 - GP-S044/S057, GP-S070 user manual
- 5) Communication cable
 - Communication cable for PC connection
 - Communication cable for controller connection
- 6) Access devices
 - (PLC or controller built in communication ports)

■ Basic operation flow

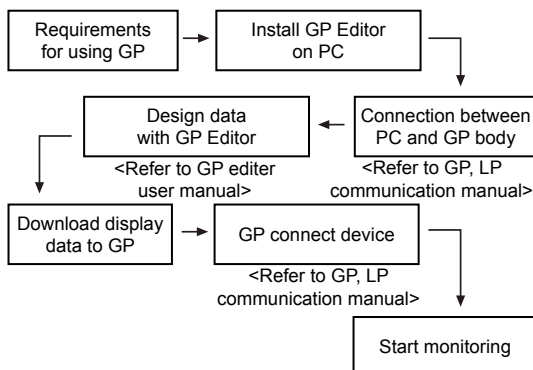

■ Advantages of using GP

◎ Complicated environment of operation and control

It graphicalizes mechanical control components such as button, switch and lamps so that saves cost and space and improves the preservation of devices.



Control part

GP-S044

◎ Setting and change of production process

It graphicalizes mechanical control components such as button, switch and lamps so that saves cost and space and improves the preservation of devices.

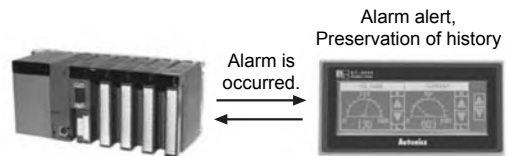

PLC

GP-S044

◎ Convenient setting by user

It sets complicated or non-displaying controller (Thermometer/hygrometer, temperature controller etc).

- 1) Temperature/Humidity without display device

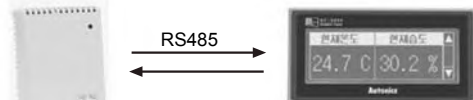

- 2) Temperature controller

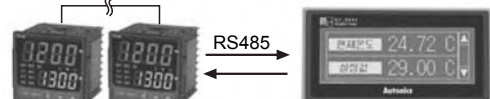

#1.....#32

Easy to set and adjust parameter.

◎ Effective data control

It prints alarm history of controller using printer. It reads the data from barcode reader and save it in PLC.

- 1) PLC/Printer



- 2) Barcode reader/PLC



◎ Communication between heterogeneous controllers



PLC

GP-S044

Thermometer/hygrometer

■ LP(Logic Panel)?

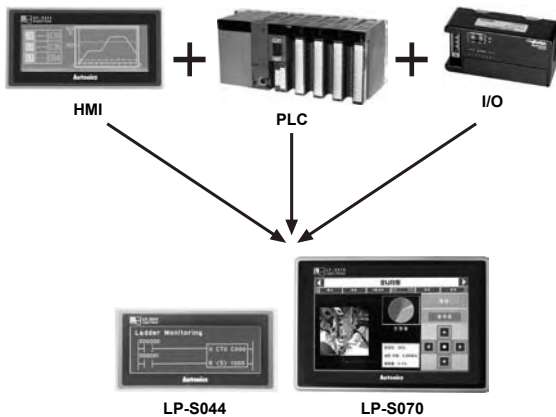

Logic panel is created for integrated panel in most demanding industrial environments that have been consisted of HMI, PLC and I/O. The LP through integration realizes cost down, wire reduction, space saving and enhanced user friendliness. The logic panel perfectly supports serial communication and editing display with GP Editor and about 250 commands of SmartStudio invented on our own to edit PLC ladder/mnemonic, allowing accelerating product development and designing. And also this device can control and monitor various output devices (sensors, button, etc) and output devices (solenoid, lamp, motor, etc) individually.

■ Preparations for using LP

- 1) LP body
- 2) PC
- 3) Software
 - ① GP Editor
 - Software for drawing LP screen
 - ② SmartStudio
 - Software for logic program
- 4) Manual
 - GP Editor user manual
 - GP,LP Communication manual
 - SmartStudio user manual
 - SmartStudio programming manual
 - LP-S044, LP-S070 user manual
 - LP series command manual
- 5) Communication cable
 - Communication cable for PC connection
 - Communication cable for controller connection
- 6) Access device
 - (PLC or controller built in communication ports)

■ Basic operation flow

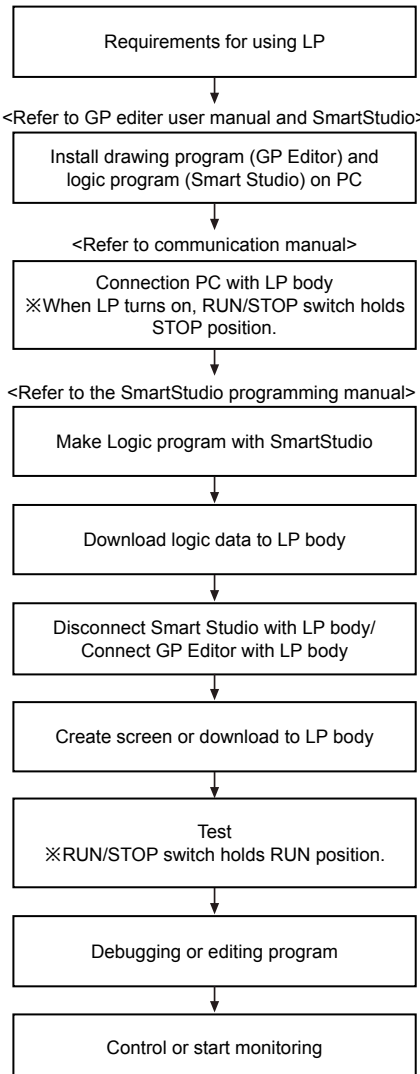

※Refer to the manual for details on website(www.autonics.com) resources.

(A)	Photo electric sensor
(B)	Fiber optic sensor
(C)	Door/Area sensor
(D)	Proximity sensor
(E)	Pressure sensor
(F)	Rotary encoder
(G)	Connector/Socket
(H)	Temp. controller
(I)	SSR/Power controller
(J)	Counter
(K)	Timer
(L)	Panel meter
(M)	Tacho/Speed/ Pulse meter
(N)	Display unit
(O)	Sensor controller
(P)	Switching mode power supply
(Q)	Stepper motor& Driver&Controller
(R)	Graphic/Logic panel
(S)	Field network device
(T)	Production stoppage models & replacement
(U)	Other

General Features

■ System configurations

◎ Stand alone(LP Series)

Stand alone system in LP series controls a variety of I/O without adding other devices and monitors and control operation element through direct touch of screen. (device, parameter, etc.)

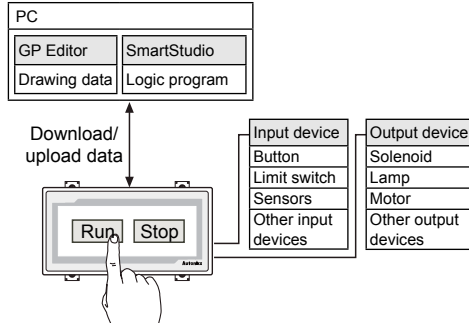

◎ 1:1:1 configuration (GP/LP Series)

The device function makes it possible to monitor, control and the operation element (device, parameter, etc.) between different devices using two separate communication port.

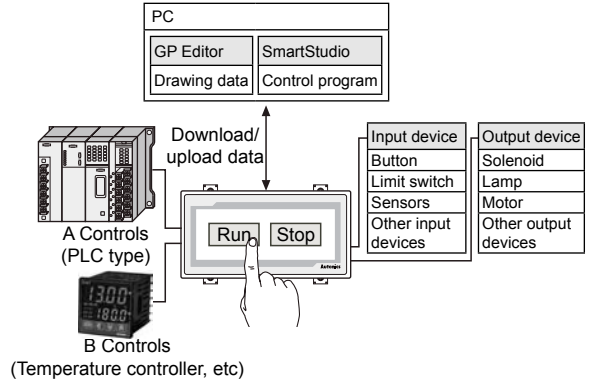

◎ 1:1 configuration (LP/GP Series)

The device function makes it possible to monitor the operation data (Device, parameter, etc.)

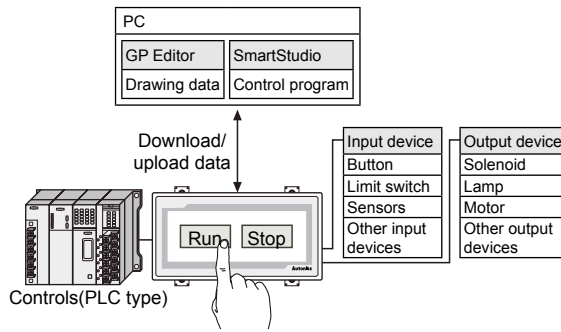

◎ 1:1 N configuration (GP/LP Series)

The device function makes it possible to monitor, control and the operation element (device, parameter, etc.) between different devices using two separate communication port.. In case of RS-422 port, 1:N is available only. (Up to 31 units).

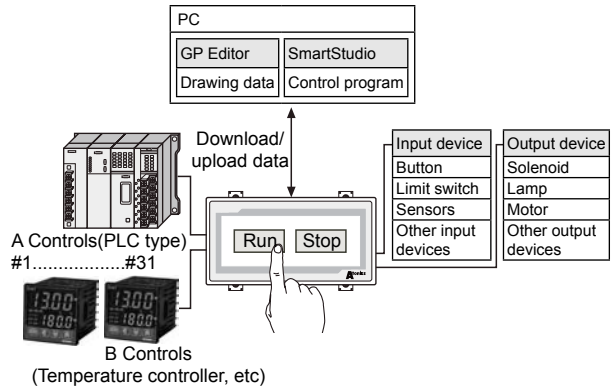

◎ 1:N configuration (LP/GP Series)

The device function makes it possible to monitor the operation element (device, parameter, etc.) by connecting in a 1:N configuration (Up to 32 units)

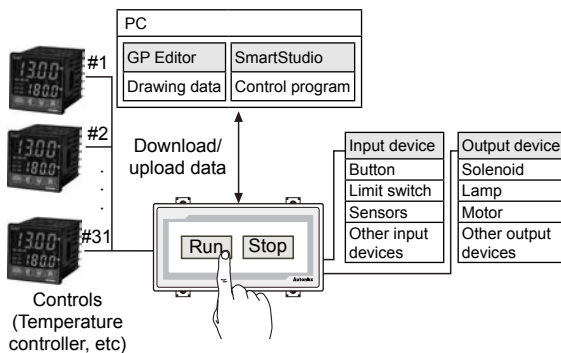

◎ Bar-code, printer connection (GP/LP Series)

It can read bar-code and print a history using printer.

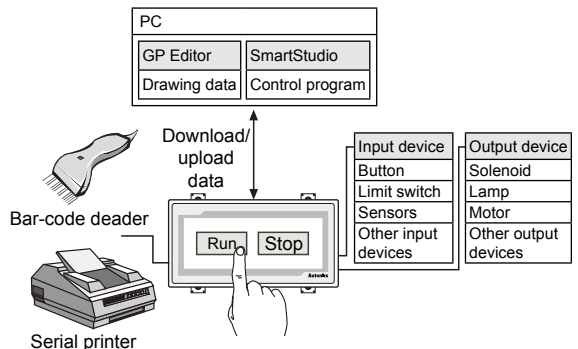

■ Software

◎ GP Editor(Drawing program)

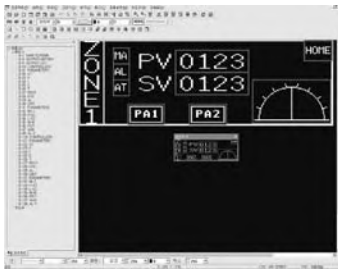

- This drawing software is for GP/LP series.
- GP Editor is the software that allows creating a screen and designs a tag layout, and then transfer the data from screen to GP/LP. After download, GP/LP starts monitoring according to your screen data.

◎ SmartStudio(Logic program)



- Logic software is for LP series.
- Support multi-project
 - : It is possible to open maximum 5 projects at a same time.
- Easy program editing
 - : Block of cell units can be edited.
 - Split-screen editing is available.
 - It provides various editing screens such as variable screen, describe screen, variable /describe screen, etc.,
- Various monitor functions
 - : It provides monitor functions such as variable monitor, device monitor and system monitor, time chart.
- Comfortable user interface
 - : It ensures easy operation with Microsoft windows layout.
- Wide range of Message windows
 - : It supports various message windows to edit and check program.
- Real time convert ladder to mnemonic
 - : Ladder and mnemonic can be written and read to edit simultaneously.

Visit our website (www.autonics.com) and download software or manuals.

< System requirements >

Item	Minimum requirements
System	IBM PC compatible computer with Intel Pentium III or above
Operating system	Microsoft Windows 98/NT/XP/Vista/7
Memory	256MB or more
Hard disk	More than 1GB of free hard disk space
VGA	1024×768 or higher resolution display
Others	RS-232 serial port(9-pin), USB port

■ Manual

◎ GP/LP common manual

- GP Editor user manual
 - This section describes how to make screen data and use HMI function with GP Editor.
- Communication manual
 - For more information of serial connection with external devices such as PLC, refer to manual before connecting.
- GP-S044/S057, GP-S070 user manual
 - The manual describes installation and system organization and menus.

◎ LP manual

- SmartStudio manual
 - This section describes how to install and use SmartStudio.
- Programming manual
 - The manual has command and instruction.
- LP-S044, LP-S070 user manual
 - The manual describes installation and system organization and menus.
- LP Series instruction manual
 - The manual has LP installation, system configuration and instruction.

■ Precaution for using

- Do not press touch panel with hard and sharp object.
- Please store the device in the recommended temperature range, or LCD panel can be damaged.
- Please check pin number shown in "Communication manual" when connect communication port
- Do not block the ventilating opening of this product.
- Do not use or store it in a place with direct ray of light or dust.
- Do not use or store it in a place with shock or vibration.
- The ground wire of GP/LP should be grounded separately. The ground resistance should be max. 100Ω, please use the wire of min. 1.25mm² dimension.
- Please check the pin number and connect to GP/LP communication port.
- Please tighten bolt on terminal block with specified tightening torque.
- When liquid crystal from the broken LCD is smeared on your skin, wash it for 15 minutes. If it is gotten in your eye, wash it for 15 minutes and contact a medical specialist for more information.
- Do not inflow dust or wire dregs into the unit.
- For cleaning, do not use water or an oil-based detergent, use dry towels.
- It should be done away regarded as an industrial waste.

(A)	Photo electric sensor
(B)	Fiber optic sensor
(C)	Door/Area sensor
(D)	Proximity sensor
(E)	Pressure sensor
(F)	Rotary encoder
(G)	Connector/Socket
(H)	Temp. controller
(I)	SSR/Power controller
(J)	Counter
(K)	Timer
(L)	Panel meter
(M)	Tacho/Speed/ Pulse meter
(N)	Display unit
(O)	Sensor controller
(P)	Switching mode power supply
(Q)	Stepper motor& Driver&Controller
(R)	Graphic/Logic panel
(S)	Field network device
(T)	Production stoppage models & replacement
(U)	Other

General Features

■ Connectable device with GP/LP

Series	Connectable device	Connection type	GP-S057	GP/LP-S044	GP/LP-S070
LS Master-K	MK-10S1	CPU direct connection loader	○	○	○
	MK-80S	CPU direct connection loader	○	○	○
	MK-120S	CPU direct connection loader	○	○	○
	MK-200S	CPU direct connection loader	○	○	○
	MK-300S	CPU direct connection loader	○	○	○
LS Glofa	MK-1000S	CPU direct connection loader	○	○	○
	GM4	CPU direct connection loader	○	○	○
	GM6	CPU direct connection loader	○	○	○
LS Glofa	GM7U	CPU direct connection loader	○	○	○
LS CNET (Cnet integrated CPU)	MK-80S	Cnet	○	○	○
	MK-120S	Cnet	○	○	○
	MK-200S	Cnet	○	○	○
LS CNET (For Cnet unit)	MK-80S	Cnet	○	○	○
	MK-120S	Cnet	○	○	○
	MK-200S	Cnet	○	○	○
	MK-300S	Cnet	○	○	○
LS XGT(For Cnet unit)	MK-1000S	Cnet	○	○	○
	XGK- PUS	Cnet	○	○	○
LS XGB (Cnet integrated CPU)	XBM	Cnet	○	○	○
	XBC	Cnet	○	○	○
LS XGB (For Cnet unit)	XBM	Cnet	○	○	○
	XBC	Cnet	○	○	○
OEMAX (SAMSUNG)	N70	Cnet	○	○	○
	N70Plus	Cnet	○	○	○
OEMAX FARA	NX7	CPU direct connection loader	○	○	○
	NX70	CPU direct connection loader	○	○	○
MITSUBISHI FX	FX1S	CPU direct connection loader	○	○	○
	FX1N	CPU direct connection loader	○	○	○
	FX2N	CPU direct connection loader	○	○	○
	FX2NC	CPU direct connection loader	○	○	○
	FX3U	CPU direct connection loader	○	○	○
MITSUBISHI Q (For Cnet unit)	Q00J	Cnet	○	○	○
	Q00	Cnet	○	○	○
	Q01	Cnet	○	○	○
	Q02	Cnet	○	○	○
	Q02H	Cnet	○	○	○
	Q06H	Cnet	○	○	○
	Q12H	Cnet	○	○	○
Q25H	Cnet	○	○	○	
NAIS FP	FP0-C10	CPU direct connection loader	○	○	○
	FP0-C14	CPU direct connection loader	○	○	○
	FP0-C16	CPU direct connection loader	○	○	○
	FP0-C32	CPU direct connection loader	○	○	○
	FPG- C24R2	CPU direct connection loader	○	○	○
	FPG- C32T	CPU direct connection loader	○	○	○
	FPG- C32T2	CPU direct connection loader	○	○	○
	FP0R-C10	CPU direct connection loader	○	○	○
	FP0R-C14	CPU direct connection loader	○	○	○
	FP0R-C1	CPU direct connection loader	○	○	○
	FP0R-C32	CPU direct connection loader	○	○	○
	FP0R-T32	CPU direct connection loader	○	○	○
	FP0R-F32	CPU direct connection loader	○	○	○
SIEMENS SIMATIC S7-200	CPU221	CPU direct connection loader	○	○	○
	CPU222	CPU direct connection loader	○	○	○
	CPU224	CPU direct connection loader	○	○	○
	CPU224XP	CPU direct connection loader	○	○	○
	CPU224Psi	CPU direct connection loader	○	○	○
	CPU226	CPU direct connection loader	○	○	○

General Features

■ Connectable device with GP/LP

Series	Connectable device	Connection type	GP-S057	GP/LP-S044	GP/LP-S070
SIEMENS SIMATIC S7-300	CPU312	CPU direct connection loader	○	○	○
	CPU312C	CPU direct connection loader	○	○	○
	CPU313C	CPU direct connection loader	○	○	○
	CPU313C-2	CPU direct connection loader	○	○	○
	CPU314	CPU direct connection loader	○	○	○
	CPU314C-2	CPU direct connection loader	○	○	○
	CPU315-2	CPU direct connection loader	○	○	○
	CPU317-2	CPU direct connection loader	○	○	○
Allen-Bradley	MicroLogix 1000	CPU direct connection loader	○	○	○
	MicroLogix 1200	CPU direct connection loader	○	○	○
	MicroLogix 1500	CPU direct connection loader	○	○	○
OMRON SYSMAC C	CPM 1A	CPU direct connection loader	○	○	○
OMRON Temperature controller	E5AN	Modbus	○	○	○
	E5AR	Modbus	○	○	○
	E5CN	Modbus	○	○	○
	E5EN	Modbus	○	○	○
	E5ER	Modbus	○	○	○
AUTONICS	MT Series	Private communication	○	○	○
		Modbus	○	○	×
		Modbus(TYPE A)	○	○	○
	MP Series	Private communication	○	○	○
		Modbus	○	○	×
	THD Series	Modbus	○	○	○
		Modbus(TYPE A)	○	○	○
	TZ Series	Private communication	○	○	○
	TK Series	Modbus	○	○	×
		Modbus(TYPE A)	○	○	○
	TM Series	Modbus	○	○	×
		Modbus(TYPE A)	○	○	○
	CT Series	Modbus	○	○	×
		Modbus(TYPE A)	○	○	○
DS/DA Series	Modbus(TYPE A)	○	○	○	
ARM Series	Modbus(TYPE A)	○	○	○	
LP-S044, LP-S070	CPU	○	○	○	
		○	○	○	
KONICS	DPU Series	Modbus	○	○	×
		Modbus(TYPE A)	○	○	○
	KRN50	Modbus	○	○	×
		Modbus(TYPE A)	○	○	○
DELTA	DTB Series	Modbus	○	○	×
		Modbus(TYPE A)	○	○	○
DANFOSS	FC Series	Modbus	×	×	×
		Modbus(TYPE A)	○	○	○
UNIVERSAL	UNIVERSAL	Modbus(Slave)	○	○	○
MODBUS MASTER	MODBUS MASTER	Modbus(Master)	○	○	○

- ※GP/LP connectable device list will keep updated according to the upgrade of GP Editor or additional patch. It is recommended to use the latest version of Editor.
- ※Applicable GP/LP firmware version is determined by GP Editor version. Whole GP system goes down if non-compatible firmware version is used.
- ※Visit our website (www.autonics.com) to check update of latest GP Editor and GP/LP firmware and to get more detailed instructions.
- ※Refer to the user manual to select proper communication cable between GP and controllers. (Sold separately)

(A) Photo electric sensor
(B) Fiber optic sensor
(C) Door/Area sensor
(D) Proximity sensor
(E) Pressure sensor
(F) Rotary encoder
(G) Connector/Socket
(H) Temp. controller
(I) SSR/Power controller
(J) Counter
(K) Timer
(L) Panel meter
(M) Tacho/Speed/Pulse meter
(N) Display unit
(O) Sensor controller
(P) Switching mode power supply
(Q) Stepper motor& Driver&Controller
(R) Graphic/Logic panel
(S) Field network device
(T) Production stoppage models & replacement
(U) Other